

(12) INTERNATIONAL APPLICATION PUBLISHED UNDER THE PATENT COOPERATION TREATY (PCT)

(19) World Intellectual Property Organization
International Bureau



(43) International Publication Date
16 January 2003 (16.01.2003)

PCT

(10) International Publication Number
WO 03/004820 A2

(51) International Patent Classification⁷: E21B
(21) International Application Number: PCT/US02/20477
(22) International Filing Date: 26 June 2002 (26.06.2002)
(25) Filing Language: English
(26) Publication Language: English
(30) Priority Data:
60/303,711 6 July 2001 (06.07.2001) US
(71) Applicant (for all designated States except US): ENVENTURE GLOBAL TECHNOLOGY [US/US]; 16200 A. Park Row, Houston, TX 77084 (US).

(81) Designated States (national): AE, AG, AL, AM, AT, AU, AZ, BA, BB, BG, BR, BY, BZ, CA, CH, CN, CO, CR, CU, CZ, DE, DK, DM, DZ, EC, EE, ES, FI, GB, GD, GE, GH, GM, HR, HU, ID, IL, IN, IS, JP, KE, KG, KP, KR, KZ, LC, LK, LR, LS, LF, LU, LV, MA, MD, MG, MK, MN, MW, MX, MZ, NO, NZ, PH, PL, PT, RO, RU, SD, SE, SG, SI, SK, SL, TJ, TM, TR, TT, TZ, UA, UG, US, UZ, VN, YU, ZA, ZW.

(84) Designated States (regional): ARIPO patent (GH, GM, KE, LS, MW, MZ, SD, SL, SZ, TZ, UG, ZM, ZW), Eurasian patent (AM, AZ, BY, KG, KZ, MD, RU, TJ, TM), European patent (AT, BE, CH, CY, DE, DK, ES, FI, FR, GB, GR, IE, IT, LU, MC, NL, PT, SE, TR), OAPI patent (BF, BJ, CF, CG, CI, CM, GA, GN, GQ, GW, ML, MR, NE, SN, TD, TG).

Declaration under Rule 4.17:

— of inventorship (Rule 4.17(iv)) for US only

Published:

— without international search report and to be republished upon receipt of that report

For two-letter codes and other abbreviations, refer to the "Guidance Notes on Codes and Abbreviations" appearing at the beginning of each regular issue of the PCT Gazette.



WO 03/004820 A2

(54) Title: LINER HANGER



(57) Abstract: An apparatus and method for forming or repairing a wellbore casing by radially expanding a tubular liner.

LINER HANGER

Cross Reference To Related Applications

This application claims the benefit of the filing date of U.S. provisional patent application serial no. 60/303,711, attorney docket no. 25791.44, filed on 7/6/2001, the disclosure of which is
5 incorporated herein by reference.

This application is related to the following: (1) U.S. patent application serial no. 09/454,139, attorney docket no. 25791.03.02, filed on 12/3/1999, (2) U.S. patent application serial no. 09/510,913, attorney docket no. 25791.7.02, filed on 2/23/2000, (3) U.S. patent application serial no. 09/502,350, attorney docket no. 25791.8.02, filed on 2/10/2000, (4) U.S. patent application serial no. 09/440,338,
10 attorney docket no. 25791.9.02, filed on 11/15/1999, (5) U.S. patent application serial no. 09/523,460, attorney docket no. 25791.11.02, filed on 3/10/2000, (6) U.S. patent application serial no. 09/512,895, attorney docket no. 25791.12.02, filed on 2/24/2000, (7) U.S. patent application serial no. 09/511,941, attorney docket no. 25791.16.02, filed on 2/24/2000, (8) U.S. patent application serial no. 09/588,946, attorney docket no. 25791.17.02, filed on 6/7/2000, (9) U.S. patent application serial no. 09/559,122,
15 attorney docket no. 25791.23.02, filed on 4/26/2000, (10) PCT patent application serial no. PCT/US00/18635, attorney docket no. 25791.25.02, filed on 7/9/2000, (11) U.S. provisional patent application serial no. 60/162,671, attorney docket no. 25791.27, filed on 11/1/1999, (12) U.S. provisional patent application serial no. 60/154,047, attorney docket no. 25791.29, filed on 9/16/1999, (13) U.S. provisional patent application serial no. 60/159,082, attorney docket no. 25791.34, filed on
20 10/12/1999, (14) U.S. provisional patent application serial no. 60/159,039, attorney docket no. 25791.36, filed on 10/12/1999, (15) U.S. provisional patent application serial no. 60/159,033, attorney docket no. 25791.37, filed on 10/12/1999, (16) U.S. provisional patent application serial no. 60/212,359, attorney docket no. 25791.38, filed on 6/19/2000, (17) U.S. provisional patent application serial no. 60/165,228, attorney docket no. 25791.39, filed on 11/12/1999, (18) U.S. provisional patent application serial no. 60/221,443, attorney docket no. 25791.45, filed on 7/28/2000, (19) U.S. provisional patent application serial no. 60/221,645, attorney docket no. 25791.46, filed on 7/28/2000,
25 (20) U.S. provisional patent application serial no. 60/233,638, attorney docket no. 25791.47, filed on 9/18/2000, (21) U.S. provisional patent application serial no. 60/237,334, attorney docket no. 25791.48, filed on 10/2/2000, (22) U.S. provisional patent application serial no. 60/270,007, attorney docket no. 25791.50, filed on 2/20/2001; (23) U.S. provisional patent application serial no. 60/262,434, attorney docket no. 25791.51, filed on 1/17/2001; (24) U.S. provisional patent application serial no. 60/259,486, attorney docket no. 25791.52, filed on 1/3/2001; and (25) U.S. provisional patent application serial no. 60/303,740, attorney docket no. 25791.61, filed on 7/6/01; the disclosures of which are incorporated herein by reference.

35

Background of the Invention

This invention relates generally to wellbor casings, and in particular to wellbore casings that are formed using expandable tubing.

Conventionally, when a wellbore is created, a number of casings are installed in the borehole
5 to prevent collapse of the borehole wall and to prevent undesired outflow of drilling fluid into the formation or inflow of fluid from the formation into the borehole. The borehole is drilled in intervals whereby a casing which is to be installed in a lower borehole interval is lowered through a previously installed casing of an upper borehole interval. As a consequence of this procedure the casing of the lower interval is of smaller diameter than the casing of the upper interval. Thus, the casings are in a
10 nested arrangement with casing diameters decreasing in downward direction. Cement annuli are provided between the outer surfaces of the casings and the borehole wall to seal the casings from the borehole wall. As a consequence of this nested arrangement a relatively large borehole diameter is required at the upper part of the wellbore. Such a large borehole diameter involves increased costs due to heavy casing handling equipment, large drill bits and increased volumes of drilling fluid and
15 drill cuttings. Moreover, increased drilling rig time is involved due to required cement pumping, cement hardening, required equipment changes due to large variations in hole diameters drilled in the course of the well, and the large volume of cuttings drilled and removed.

The present invention is directed to overcoming one or more of the limitations of the existing procedures for forming wellbores and wellheads.

20

Summary of the Invention

According to one aspect of the present invention, a method of coupling a radially expandable tubular member to a preexisting structure is provided that includes positioning the tubular member within the preexisting structure, injecting fluidic materials into the tubular member, sensing the operating pressure of the fluidic materials, and radially expanding the tubular member into contact
25 with the preexisting structure when the sensed operating pressure exceeds a predetermined amount.

According to another aspect of the present invention, an apparatus for coupling a radially expandable tubular member to a preexisting structure is provided that includes a first tubular support member, an expansion cone assembly, an expansion cone launcher, and a shoe assembly. The first tubular support includes a first internal passage. The expansion cone assembly includes a second
30 tubular support including a second internal passage operably coupled to the first internal passage. one or more radial openings, and a first releasable coupling, one or more pressure relief valves positioned in corresponding ones of the radial openings, and an annular expansion cone coupled to the second tubular support. The expansion cone launcher is coupled to the annular expansion cone and the radially expandable tubular member. The shoe assembly includes a third tubular support member
35 including a third internal passage operably coupled to the second internal passage and having a restriction, and a second releasable coupling releasably coupled to the first releasable coupling.

Brief Description of the Drawings

FIGS. 1 and 1a-1d are fragmentary cross-sectional illustrations of an embodiment of a liner hanger.

5 FIGS. 2a-2d are fragmentary cross-sectional illustrations of the placement of the liner hanger of FIGS. 1a-1d into a wellbore.

FIGS. 3a-3d are fragmentary cross-sectional illustrations of the release of the bottom SSR plug from the apparatus of FIGS. 2a-2d.

FIGS. 4a-4d are fragmentary cross-sectional illustrations of the release of the top SSR plug from the apparatus of FIGS. 3a-3d.

10 FIGS. 5a-5c are fragmentary cross-sectional illustrations of the initiation of the radial expansion process for the apparatus of FIGS. 4a-4d.

FIGS. 6a-6c are fragmentary cross-sectional illustrations of the continuation of the radial expansion process for the apparatus of FIGS. 5a-5c.

15 FIGS. 7a-7c are fragmentary cross-sectional illustrations of the drilling out of the collar upon the completion of radial expansion process for the apparatus of FIGS. 6a-6c.

FIGS. 8a and 8b are cross sectional illustrations of an alternative embodiment of an expansion cone assembly for use in the apparatus of FIGS. 1a-1d.

Detailed Description of the Illustrative Embodiments

20 An apparatus and method for plastically deforming a tubular liner within a wellbore within a subterranean formation is provided. The apparatus and method thereby provides a system for coupling a radially expandable tubular liner to an open hole or cased section of a wellbore within a subterranean formation. Furthermore, in this manner, a wellbore casing, a pipeline, or a structural support may be formed or repaired using the present illustrative embodiments.

25 Referring initially to Figs. 1a-1d, an embodiment of an apparatus 100 for radially expanding and plastically deforming a tubular liner includes a tubular hanger joint 105 coupled to a tubular expansion cone launcher 110. The tubular hanger joint 105 includes a first section 105a, a first transition section 105b, an intermediate section 105c, a second transition section 105d, and a second section 105e. The outside diameter of the first and second sections, 105a and 105e, are preferably less than the outside diameter of the intermediate section 105c. The intermediate section 105c preferably
30 further includes radially directed coupling elements 105ca-105cd affixed to the outside surface of the intermediate section 105c for enhancing the connection of the tubular hanger joint 105 to a preexisting structure following the radial expansion of the tubular hanger joint using the apparatus 100.

35 The expansion cone launcher 110 includes an upper tubular portion 110a, an intermediate tubular portion 110b, and a lower tubular portion 110c. In a preferred embodiment, the outside diameter of the upper portion 110a is less than the outside diameter of the lower portion 110c in order to facilitate the placement of the apparatus 100 within a wellbore, or other tubular member. In a

preferred embodiment, the wall thickness of the intermediate portion 110b is less than the wall thickness of the upper and lower portions, 110a and 110c, in order to facilitate the initiation of the radial expansion of the expansion cone launcher 110.

5 An expansion cone assembly 115 is positioned within the expansion cone launcher 110 that includes a tubular coupling 120 that includes a conventional threaded coupling element 120a at one end for coupling the tubular coupling to a conventional support member and a threaded counterbore 120b at another end for coupling the tubular coupling to an end of a first tubular support 125. The tubular coupling 120 further includes an internal passage 120c for conveying fluidic materials.

10 The first tubular support 125 includes an internal passage 125a for conveying fluidic materials and an annular flange 125b, openings 125ca and 125cb, and a releasable coupling 125d at another end. In an exemplary embodiment, the releasable coupling 125d is a conventional collet assembly having a plurality of resilient collet fingers. A second tubular support 130 includes an opening 130a at one end for receiving an end of the first tubular support 125, a counterbore 130b, first and second shoulders, 130c and 130d, an inwardly directed annular flange 130e, and a threaded connection 130f
15 at another end. An expansion cone 135 that mates with the interior surface of the expansion cone launcher 110 includes an opening 135a and a counterbore 135b at one end for receiving an end of the second tubular support 130 and receiving an annular spacer 140, respectively, a counterbore 135c at another end for receiving the shoulder 130c of the second tubular support, and an end face 135d that mates with the shoulder 130d of the second tubular support.

20 The annular spacer 140 is positioned receives an end of the first tubular support 125 and is positioned within the counterbore 135b of the expansion cone 135 between the end face of the tubular coupling 120 and the end faces of the first tubular support and the counterbore of the expansion cone. An end of a third tubular support 145 is received within the counterbore 130b of the second tubular support 130, and another end of the third tubular support abuts an end of a fourth tubular support 150.
25 The fourth tubular support 150 includes one or more longitudinal passages, 150a and 150b, for conveying fluidic materials, and an end of the fourth tubular support mates with the annular flange 125b of the first tubular support 125.

A fifth tubular support 155 includes an annular recess 155a at an end that mates with the annular flange 130e of the second tubular support 130, and another end of the fifth tubular support
30 includes an annular recess 155b that mates with an end of a fourth tubular support 150. An end of a sixth tubular support 160 is threadably coupled to the threaded connection 130f of the second tubular support 130, and another end of the sixth tubular support mates with the interior surface of the lower portion 110c of the expansion cone launcher 110.

35 Burst discs 165a and 165b are received within the openings 125ca and 125cb of the first tubular support member 125 in order to controllably permit fluidic materials to pass from the passage 125 into a first annular region 170 defined by the annular region between the first tubular support

member 125, the second tubular support member 130, and the sixth tubular support member 160, the passages 150a and 150b, and a second annular region 175 defined by the annular region between the second tubular support 130, the third tubular support 145 and the fifth tubular support 155.

5 A shoe assembly 180 is coupled to the expansion cone launcher 110 and releasably coupled to the expansion cone assembly 115. The shoe assembly 180 includes a tubular support member 185 that includes a releasable coupling 185a at an end that is releasably coupled to the releasable coupling 125d of the first tubular support member 125 and a threaded connection 185b at another end. In an exemplary embodiment, the releasable coupling 185a includes a plurality of radial splines that releasably engage the releasable coupling 125d. In this manner, the connection between the
10 releasable coupling 125d and the releasable coupling 185a may transmit torque. The tubular support member 185 further includes an internal passage 185c for conveying fluidic materials that includes a restriction 185ca for receiving a conventional wiper plug, or other similar device, and a plurality of radially directed ribs 185d.

15 An end of a tubular sealing sleeve 190 includes an annular recess 190a for receiving the lower portion 110c of the expansion cone launcher 110, and another end of the sealing sleeve includes a threaded connection 190b. The interior of sealing sleeve 190 further includes a plurality of radially directed ribs 190c. The sealing sleeve 190 is coupled to the end of the lower portion 110c of the expansion cone launcher 110 by a plurality of pinned connections 195. An annular body 200 of a cured cement is positioned between the tubular support member 185 and the sealing sleeve 190. In a
20 preferred embodiment, the sealing sleeve 190 and the annular body 200 are fabricated from materials that may be drilled out using conventional drilling equipment. In an exemplary embodiment, the sealing sleeve 190 and the annular body 200 are fabricated from aluminum and cement, respectively.

25 An end of a tubular member 205 is coupled to the threaded connection 190b of the sealing sleeve 190. An end of a conventional tubular coupling 210 is coupled to threaded connection 185b of the tubular support 185 and another end of the tubular coupling 210 is coupled to a conventional SSR plug set 215 including an upper and lower SSR plugs, 215a and 215b. The tubular coupling 210 and the SSR plug set 215 are contained within the tubular member 205. The tubular coupling 210 includes an internal passage 210a for conveying fluidic materials, and the upper and lower SSR plugs, 215a and 215b, include internal passages, 215aa and 215ba, respectively, for conveying fluidic
30 materials.

35 In a preferred embodiment, the apparatus 100 is provided as disclosed in one or more of the following: (1) U.S. patent application serial no. 09/454,139, attorney docket no. 25791.03.02, filed on 12/3/1999, (2) U.S. patent application serial no. 09/510,913, attorney docket no. 25791.7.02, filed on 2/23/2000, (3) U.S. patent application serial no. 09/502,350, attorney docket no. 25791.8.02, filed on 2/10/2000, (4) U.S. patent application serial no. 09/440,338, attorney docket no. 25791.9.02, filed on 11/15/1999, (5) U.S. patent application serial no. 09/523,460, attorney docket no. 25791.11.02, filed

on 3/10/2000, (6) U.S. patent application serial no. 09/512,895, attorney docket no. 25791.12.02, filed on 2/24/2000, (7) U.S. patent application serial no. 09/511,941, attorney docket no. 25791.16.02, filed on 2/24/2000, (8) U.S. patent application serial no. 09/588,946, attorney docket no. 25791.17.02, filed on 6/7/2000, (9) U.S. patent application serial no. 09/559,122, attorney docket no. 25791.23.02, filed
5 on 4/26/2000, (10) PCT patent application serial no. PCT/US00/18635, attorney docket no. 25791.25.02, filed on 7/9/2000, (11) U.S. provisional patent application serial no. 60/162,671, attorney docket no. 25791.27, filed on 11/1/1999, (12) U.S. provisional patent application serial no. 60/154,047, attorney docket no. 25791.29, filed on 9/16/1999, (13) U.S. provisional patent application serial no. 60/159,082, attorney docket no. 25791.34, filed on 10/12/1999, (14) U.S. provisional patent
10 application serial no. 60/159,039, attorney docket no. 25791.36, filed on 10/12/1999, (15) U.S. provisional patent application serial no. 60/159,033, attorney docket no. 25791.37, filed on 10/12/1999, (16) U.S. provisional patent application serial no. 60/212,359, attorney docket no. 25791.38, filed on 6/19/2000, (17) U.S. provisional patent application serial no. 60/165,228, attorney docket no. 25791.39, filed on 11/12/1999, (18) U.S. provisional patent application serial no.
15 60/221,443, attorney docket no. 25791.45, filed on 7/28/2000, (19) U.S. provisional patent application serial no. 60/221,645, attorney docket no. 25791.46, filed on 7/28/2000, (20) U.S. provisional patent application serial no. 60/233,638, attorney docket no. 25791.47, filed on 9/18/2000, (21) U.S. provisional patent application serial no. 60/237,334, attorney docket no. 25791.48, filed on 10/2/2000, (22) U.S. provisional patent application serial no. 60/270,007, attorney docket no. 25791.50, filed on
20 2/20/2001; (23) U.S. provisional patent application serial no. 60/262,434, attorney docket no. 25791.51, filed on 1/17/2001; (24) U.S. provisional patent application serial no. 60/259,486, attorney docket no. 25791.52, filed on 1/3/2001; and (25) U.S. provisional patent application serial no. 60/303,740, attorney docket no. 25791.61, filed on 7/6/01, the disclosures of which are incorporated herein by reference.

25 Referring to Figs. 2a-2d, during operation, the apparatus 100 is positioned within a wellbore 220 within a subterranean formation 225. The wellbore 220 may include one or more preexisting sections of wellbore casing, and the wellbore 220 may be positioned in any orientation from the vertical to the horizontal. In order to position the apparatus 100 within the wellbore 220, a tubular support 230 having an internal passage 230a for conveying fluidic materials is coupled to the threaded
30 coupling element 120a of the tubular coupling 120. During placement of the apparatus 100 within the wellbore 220, fluidic materials 235 within the wellbore that are displaced by the apparatus 100 are conveyed through the fluid passages 215ba, 215aa, 210a, 185c, 125a, 120c, and 230a to a location above the apparatus 100. In this manner, surge pressures during placement of the apparatus 100 within the wellbore 220 are minimized. In a preferred embodiment, the apparatus 100 is initially
35 positioned within the wellbore 220 with the tubular member 105 in opposing relation to a preexisting

section of a wellbore casing. In this manner, the tubular member 105 may be radially expanded into contact with the pre existing wellbore casing.

Referring to Figs. 3a-3d, once the apparatus 100 has been positioned at the predetermined initial position within the wellbore 220, fluidic materials 240 may then be injected into the apparatus 100 using the passage 230a. The fluidic materials 240 may then pass through and out of the apparatus 100 using the passages 120c, 125a, 185c, 210a, 215aa, and 215ba. In this manner, the proper functioning of the passages 210a, 120c, 125a, 185c, 210a, 215aa, and 215ba may be determined. A ball 245, or other similar device, may then be introduced into the fluidic material 240 in order to release the lower SSR plug 215b in a well known manner.

Referring to Figs. 4a-4d, the upper SSR plug 215a may then be released in a well known manner by introducing another ball, or other similar device, into the fluidic material 240.

Referring to Figs. 5a-5c, a conventional dart, ball, or other similar device 245 may then be introduced into the fluidic material 240 and positioned in the restriction 185ca in the passage 185c of the tubular support 185. In this manner the region above the restriction 185ca is fluidically isolated from the region below the restriction. Continued injection of the fluidic material 240 following the placement of the dart 245 in the restriction 185ca will then increase the operating pressure within the passages 230a, 120c, and 125a upstream of the restriction 185ca. The increased operating pressure in turn will rupture one or more of the rupture discs, 165a and 165b. In this manner, the pressurized fluidic material 240 will flow through the passages 125ca and 125cb into the passages 170, 150a, 150b, and 175.

Referring to Figs. 6a-6c, the releasable coupling 125d and the releasable coupling 185a are then decoupled and the continued pressurization of the fluidic materials 240 displaces the expansion cone assembly 115 away from the shoe assembly 180 in the longitudinal direction. In this manner, the expansion cone launcher 110 and the expandable tubular member 105 are radially expanded and thereby plastically deformed. In a preferred embodiment, the expansion cone launcher 110 and the expandable tubular member 105 are radially expanded into contact with the interior surface of the wellbore 220, or other tubular member such as, for example, a wellbore casing, a pipeline, or a structural support. In a preferred embodiment, the expandable tubular member 105 includes a plurality of expandable tubular members 105 coupled end to end. In several alternative embodiment, the releasable coupling 125d and the releasable coupling 185a are then decoupled manually and/or automatically as a function of the operating pressure upstream of the restriction 185ca.

Referring to Figs. 7a-7c, after the completion of the radial expansion of the expandable tubular member 105 and the expansion cone launcher 110, the expansion cone assembly 115 is removed from the wellbore 220, and the internal elements of the shoe assembly 180 are drilled out.

In a preferred embodiment, the radial expansion of the expandable tubular member 105 and the expansion cone launcher 110 is provided substantially as disclosed in one or more of the

following: (1) U.S. patent application serial no. 09/454,139, attorney docket no. 25791.03.02, filed on 12/3/1999, (2) U.S. patent application serial no. 09/510,913, attorney docket no. 25791.7.02, filed on 2/23/2000, (3) U.S. patent application serial no. 09/502,350, attorney docket no. 25791.8.02, filed on 2/10/2000, (4) U.S. patent application serial no. 09/440,338, attorney docket no. 25791.9.02, filed on 11/15/1999, (5) U.S. patent application serial no. 09/523,460, attorney docket no. 25791.11.02, filed on 3/10/2000, (6) U.S. patent application serial no. 09/512,895, attorney docket no. 25791.12.02, filed on 2/24/2000, (7) U.S. patent application serial no. 09/511,941, attorney docket no. 25791.16.02, filed on 2/24/2000, (8) U.S. patent application serial no. 09/588,946, attorney docket no. 25791.17.02, filed on 6/7/2000, (9) U.S. patent application serial no. 09/559,122, attorney docket no. 25791.23.02, filed on 4/26/2000, (10) PCT patent application serial no. PCT/US00/18635, attorney docket no. 25791.25.02, filed on 7/9/2000, (11) U.S. provisional patent application serial no. 60/162,671, attorney docket no. 25791.27, filed on 11/1/1999, (12) U.S. provisional patent application serial no. 60/154,047, attorney docket no. 25791.29, filed on 9/16/1999, (13) U.S. provisional patent application serial no. 60/159,082, attorney docket no. 25791.34, filed on 10/12/1999, (14) U.S. provisional patent application serial no. 60/159,039, attorney docket no. 25791.36, filed on 10/12/1999, (15) U.S. provisional patent application serial no. 60/159,033, attorney docket no. 25791.37, filed on 10/12/1999, (16) U.S. provisional patent application serial no. 60/212,359, attorney docket no. 25791.38, filed on 6/19/2000, (17) U.S. provisional patent application serial no. 60/165,228, attorney docket no. 25791.39, filed on 11/12/1999, (18) U.S. provisional patent application serial no. 60/221,443, attorney docket no. 25791.45, filed on 7/28/2000, (19) U.S. provisional patent application serial no. 60/221,645, attorney docket no. 25791.46, filed on 7/28/2000, (20) U.S. provisional patent application serial no. 60/233,638, attorney docket no. 25791.47, filed on 9/18/2000, (21) U.S. provisional patent application serial no. 60/237,334, attorney docket no. 25791.48, filed on 10/2/2000, (22) U.S. provisional patent application serial no. 60/270,007, attorney docket no. 25791.50, filed on 2/20/2001; (23) U.S. provisional patent application serial no. 60/262,434, attorney docket no. 25791.51, filed on 1/17/2001; (24) U.S. provisional patent application serial no. 60/259,486, attorney docket no. 25791.52, filed on 1/3/2001; and (25) U.S. provisional patent application serial no. 60/303,740, attorney docket no. 25791.61, filed on 7/6/01, the disclosures of which are incorporated herein by reference.

Referring to Figs. 8a and 8b, in an alternative embodiment, the apparatus 100 includes an expansion cone assembly 300 that includes a tubular coupling 305 having a conventional threaded coupling element 305a at one end for coupling the tubular coupling to a conventional support member and a threaded counterbore 305b at another end for coupling the tubular coupling to an end of a first tubular support 310. The tubular coupling 305 further includes an internal passage 305c for conveying fluidic materials.

The first tubular support 310 includes an internal passage 310a for conveying fluidic materials and an annular flange 310b, openings 310ca and 310cb, and a releasable coupling 310d at another end. A second tubular support 315 includes an opening 315a at one end for receiving an end of the first tubular support 310, an annular flange 315b at one end, an annular flange 315c at another end including longitudinal passages 315ca and 315cb and an opening 315cc for receiving another end of the first tubular support 310, and an annular recess 315d at the other end.

A first expansion cone retainer 320 includes an opening 320a for receiving an end of the second tubular support 315 and a counterbore 320b. The first expansion cone retainer 320 preferably mates with the expansion cone launcher 110. A first expansion cone 325 includes an opening 325a for receiving the second tubular support 315, an annular recess 325b, and an annular recess 325c. The first expansion cone 325 preferably mates with the first expansion cone retainer 320 and the expansion cone launcher 110.

A second expansion cone retainer 330 includes an opening 330a for receiving the second tubular support 315, an annular recess 330b, and an annular recess 330c. A second expansion cone 335 includes an opening 335a for receiving the second tubular support 315, an annular recess 335b, and an annular recess 335c. The second expansion cone 335 preferably mates with the second expansion cone retainer 330 and the expansion cone launcher 110.

A third expansion cone retainer 340 includes a counterbore 340a for mating with the second expansion cone 335, a counterbore 340b for mating with the annular recess 315d of the second tubular support, and an opening 340c for defining an annular passage 345. Another annular passage 350 is defined by the annular space between the first tubular support 310 and the second tubular support 315.

Burst discs 355a and 355b are positioned in the openings 310ca and 310cb, respectively, in order to controllably permit pressurized fluidic materials to pass from the passage 310a into the passages 345, 315ca, 315cb, and 350.

It is understood that variations may be made in the foregoing without departing from the scope of the invention. For example, the apparatus 100 may be used to form and/or repair, for example, a wellbore casing, a pipeline, or a structural support. Furthermore, the burst discs 165a, 165b, 355a, and 355b may be replaced with conventional pressure relief valves.

Although illustrative embodiments of the invention have been shown and described, a wide range of modification, changes and substitution is contemplated in the foregoing disclosure. In some instances, some features of the present invention may be employed without a corresponding use of the other features. Accordingly, it is appropriate that the appended claims be construed broadly and in a manner consistent with the scope of the invention.

Claims

What is claimed is:

- 1 1. A method of coupling a radially expandable tubular member to a preexisting structure,
2 comprising:
3 positioning the tubular member within the preexisting structure;
4 injecting fluidic materials into the tubular member;
5 sensing the operating pressure of the fluidic materials; and
6 radially expanding the tubular member into contact with the preexisting structure when the
7 sensed operating pressure exceeds a predetermined amount.
- 1 2. The method of claim 1, wherein sensing the operating pressure includes:
2 sensing the operating pressure of the fluidic materials within the tubular member.
- 1 3. An apparatus for coupling a radially expandable tubular member to a preexisting structure,
2 comprising:
3 a first tubular support member including a first internal passage;
4 an expansion cone assembly including:
5 a second tubular support including a second internal passage operably coupled to the
6 first internal passage, one or more radial openings, and a first releasable
7 coupling;
8 one or more pressure relief valves positioned in corresponding ones of the radial
9 openings; and
10 one or more annular expansion cones coupled to the second tubular support;
11 an expansion cone launcher coupled to the annular expansion cones and the radially
12 expandable tubular member; and
13 a shoe assembly, comprising:
14 a third tubular support member including a third internal passage operably coupled to
15 the second internal passage and having a restriction, and a second releasable
16 coupling releasably coupled to the first releasable coupling.
- 1 4. The apparatus of claim 3, wherein the expansion cone assembly includes a plurality of spaced
2 apart annular expansion cone
- 1 5. A system for coupling a radially expandable tubular member to a preexisting structure,
2 comprising:

3 means for positioning the tubular member within the preexisting structure;
4 means for injecting fluidic materials into the tubular member;
5 means for sensing the operating pressure of the fluidic materials; and
6 means for radially expanding the tubular member into contact with the preexisting structure
7 when the sensed operating pressure exceeds a predetermined amount.

1 6. The system of claim 5, wherein the means for sensing the operating pressure includes:
2 means for sensing the operating pressure of the fluidic materials within the tubular member.



FIG. 1

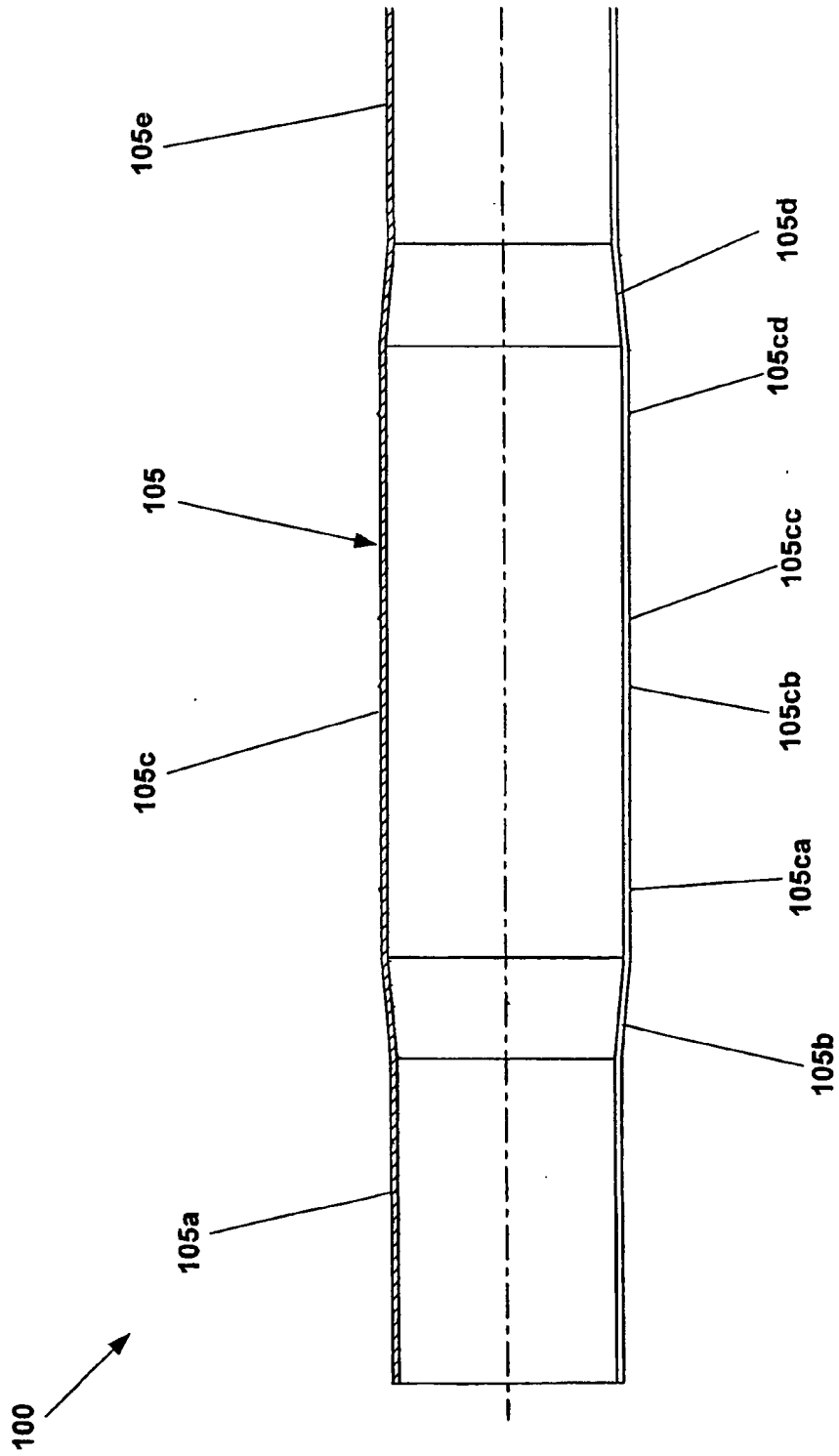

FIG.1a

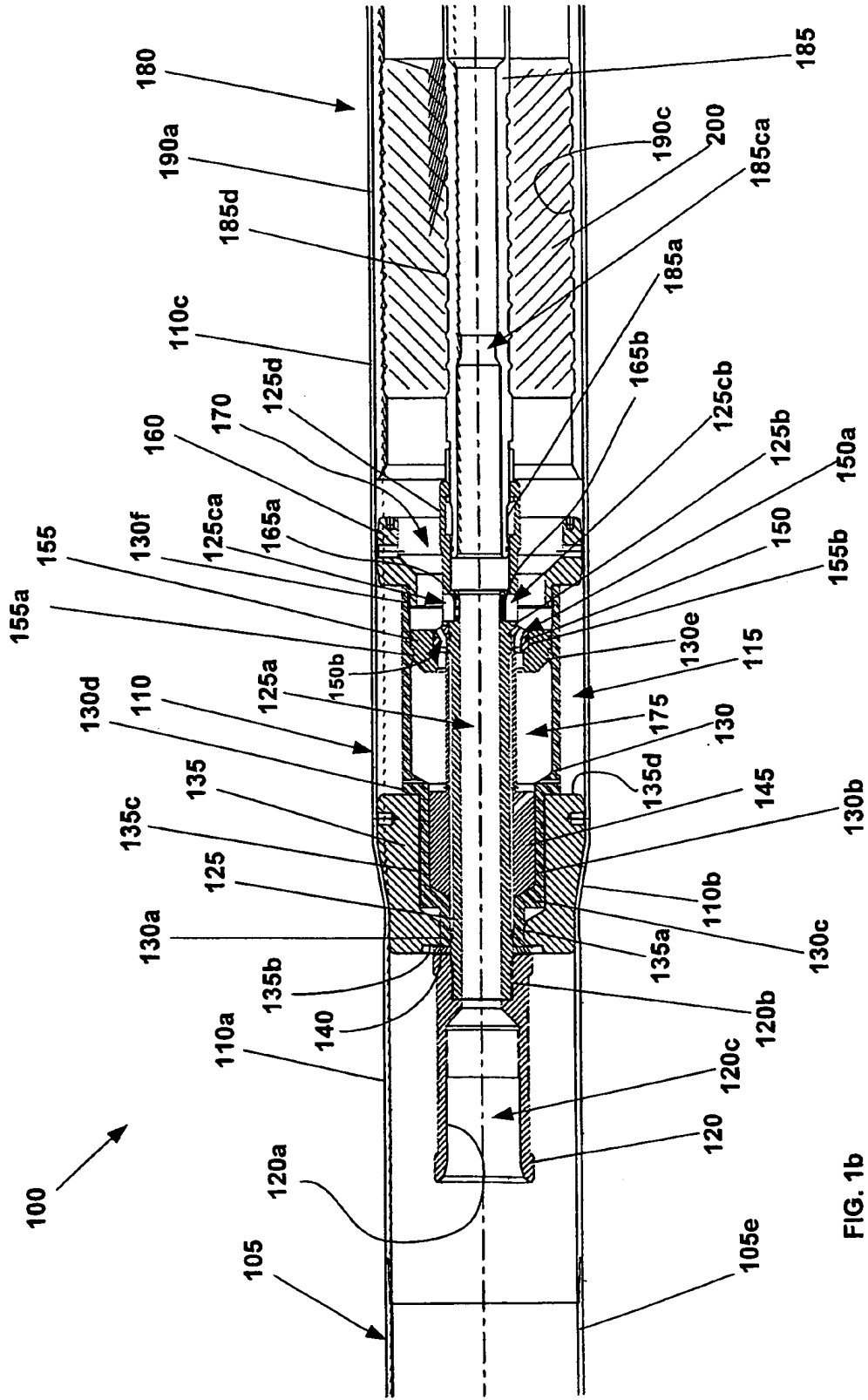
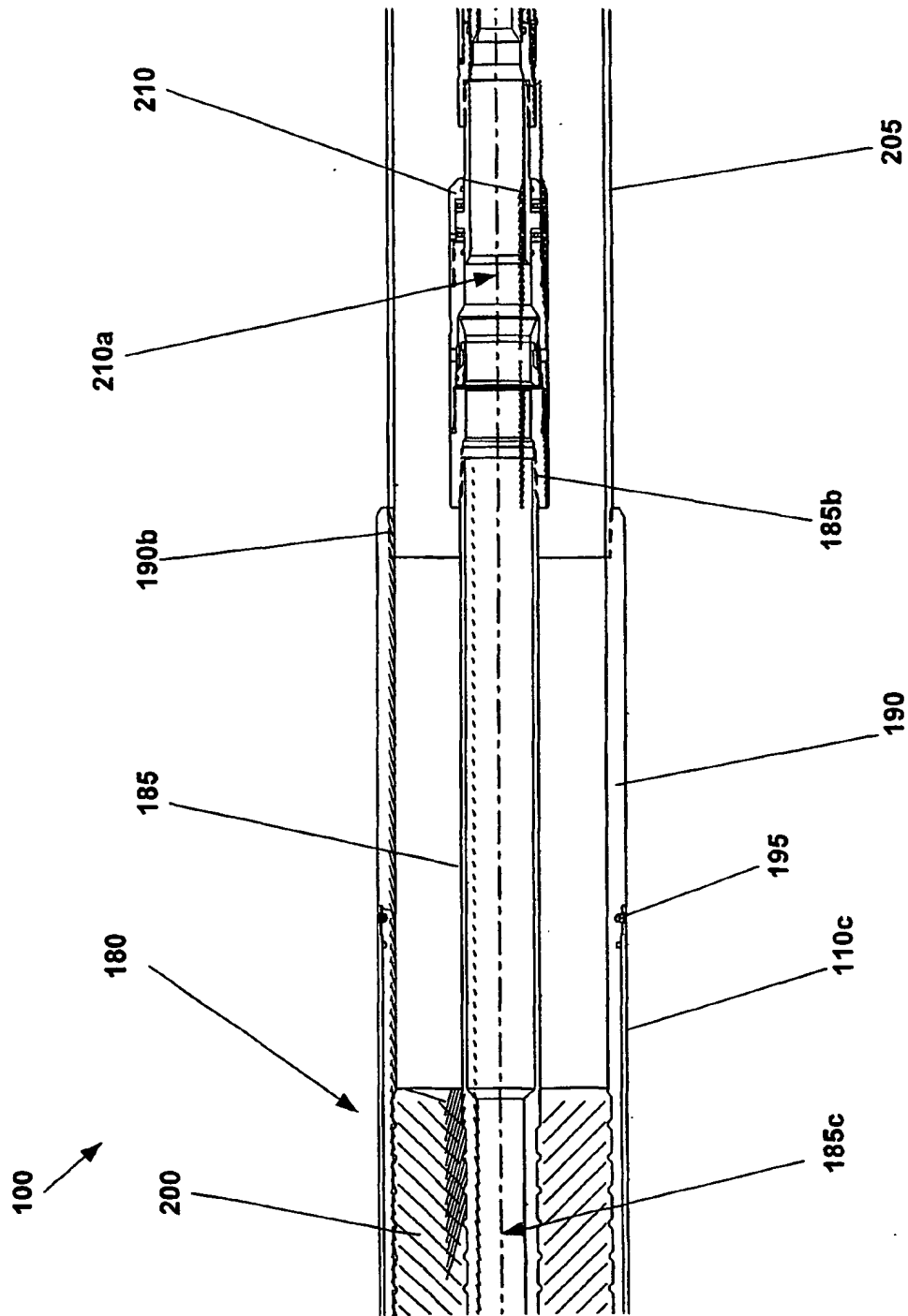

FIG. 1b



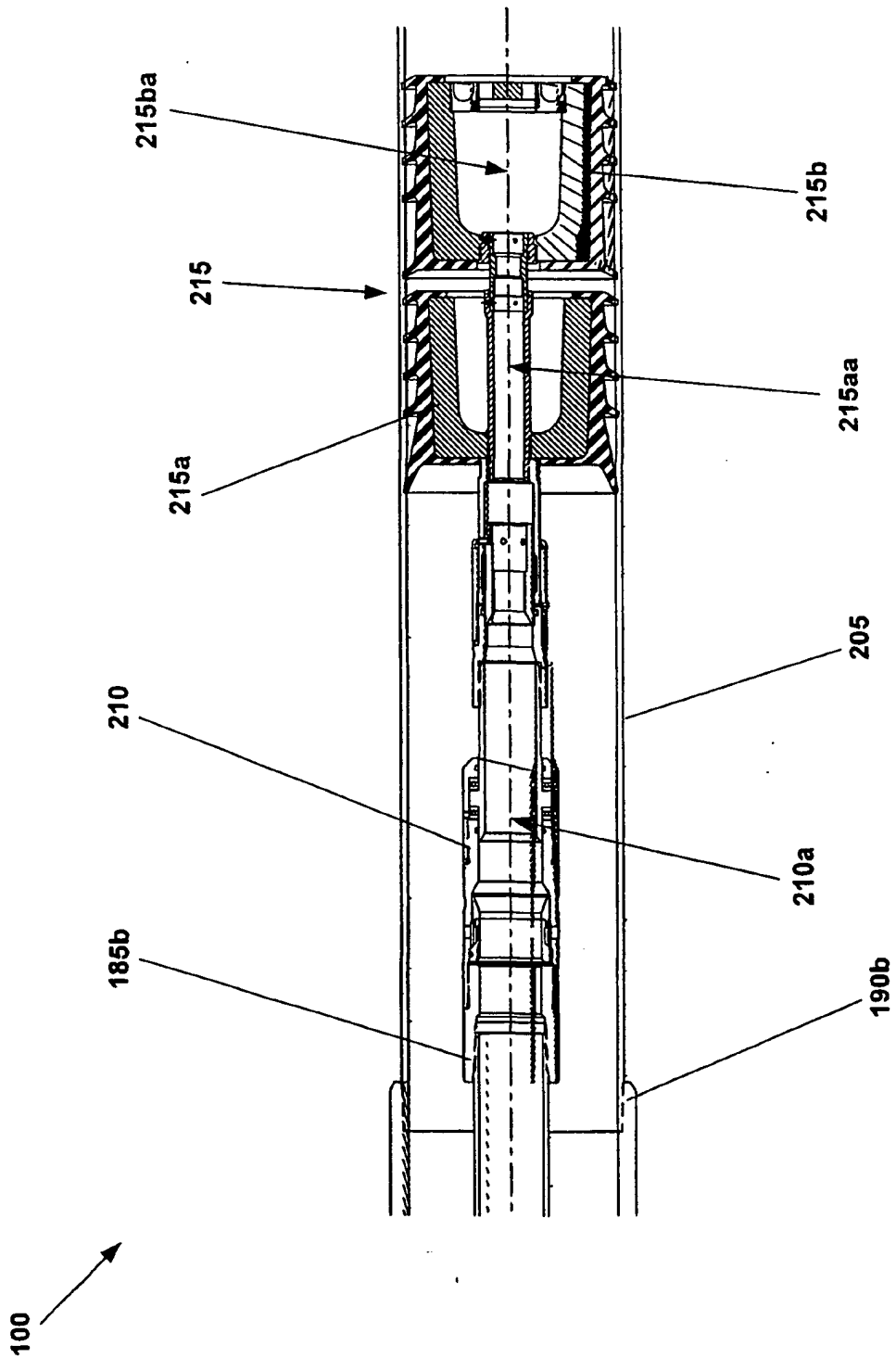

FIG. 1d

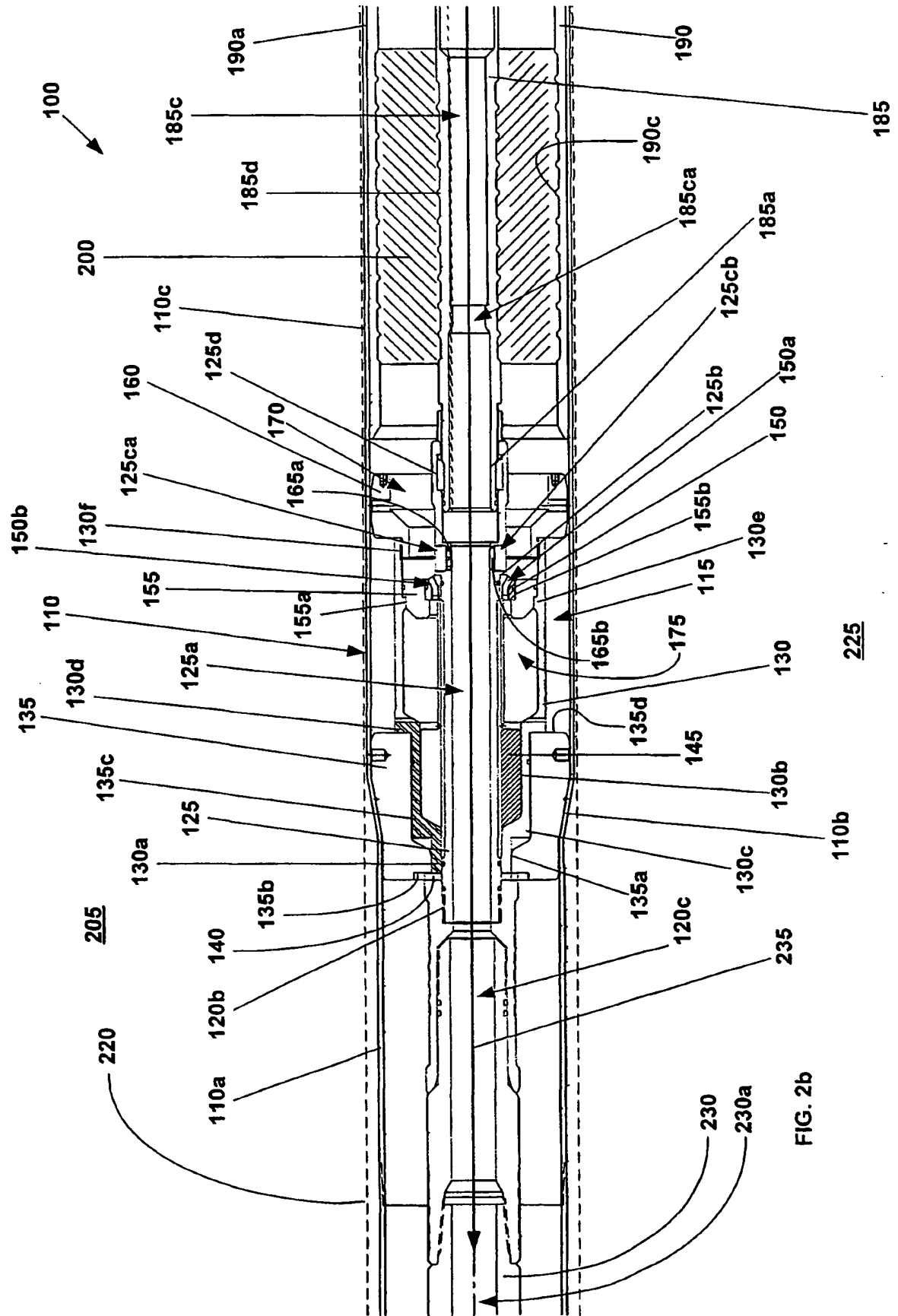
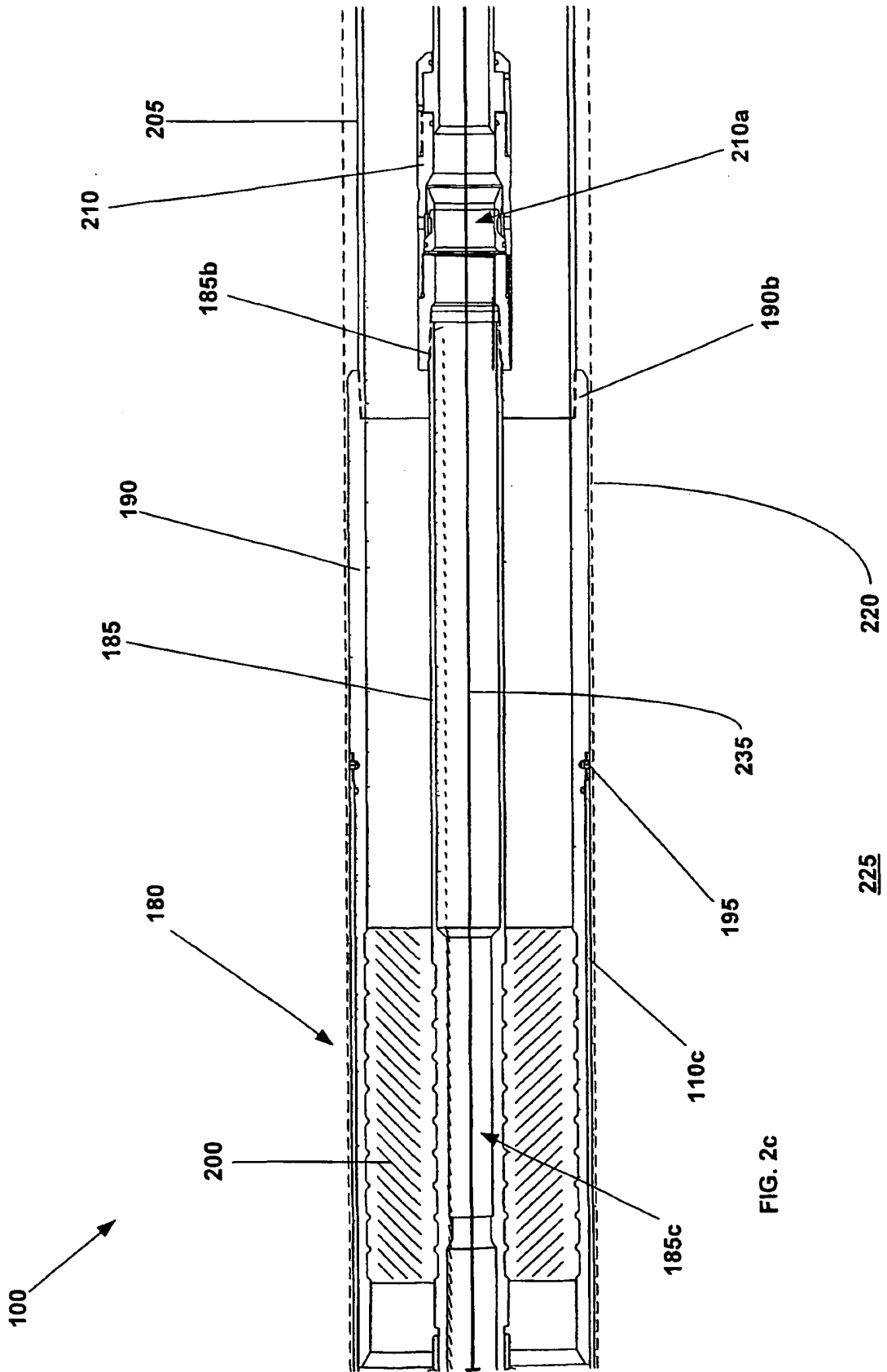

FIG. 2b



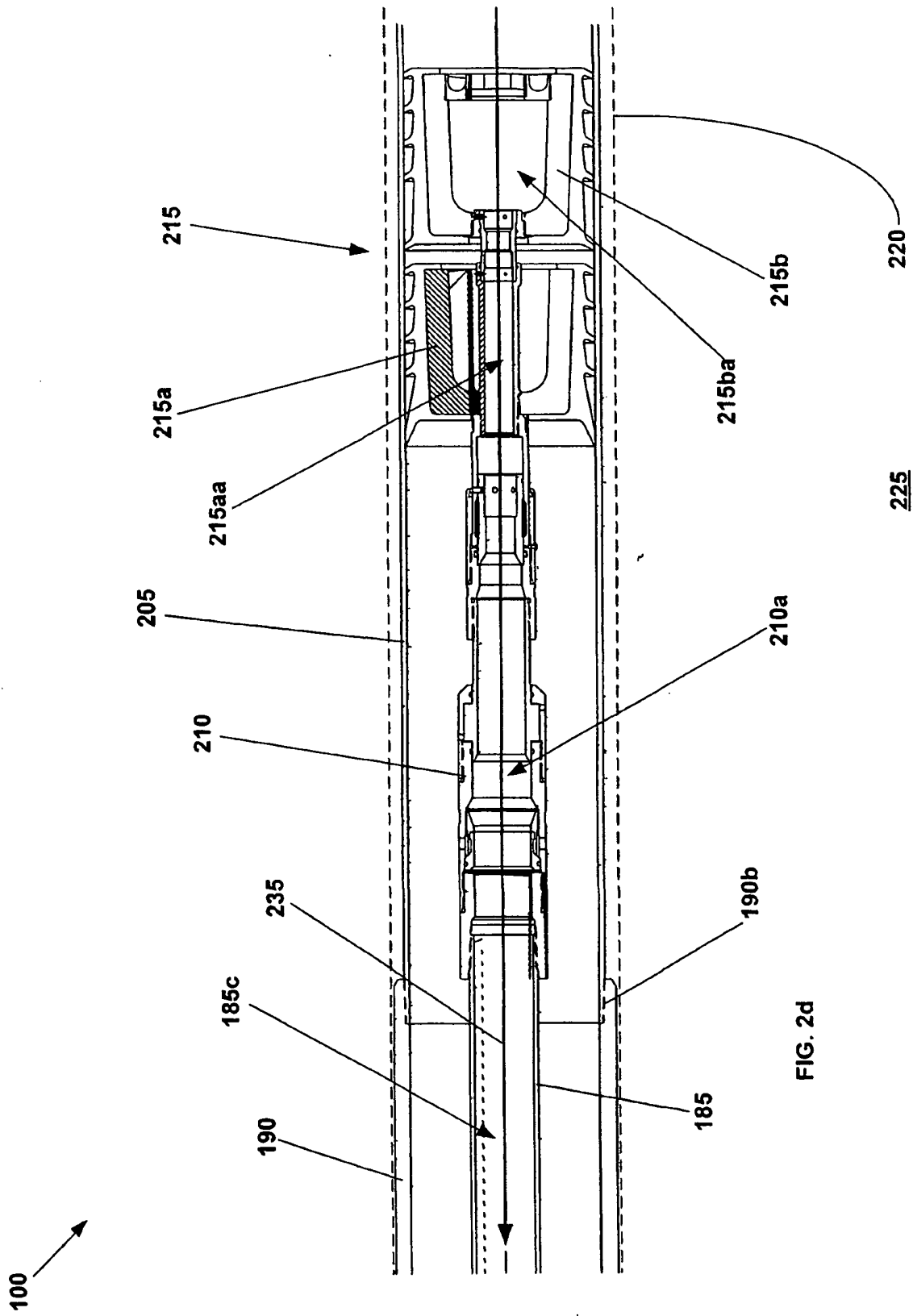

FIG. 2d

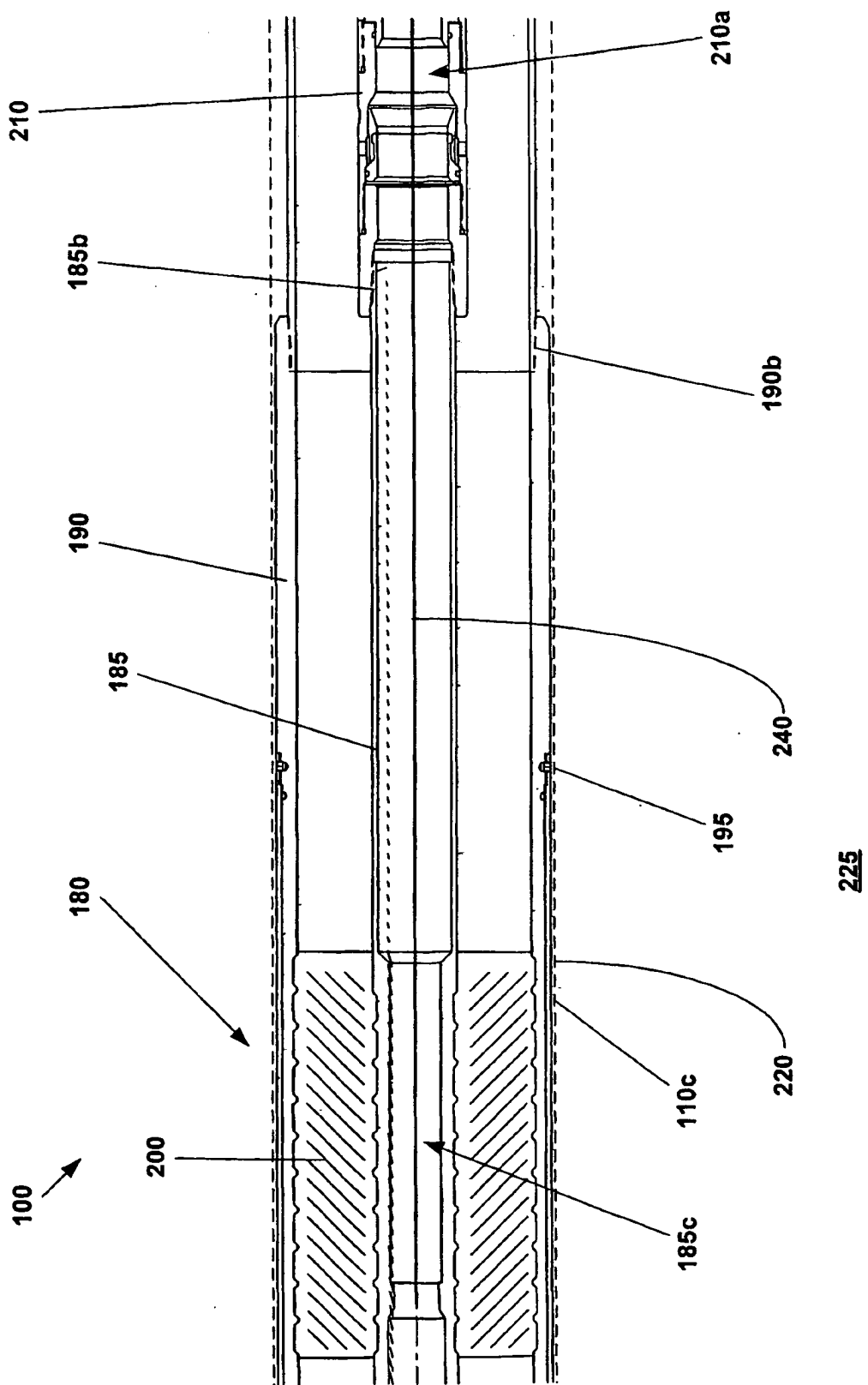
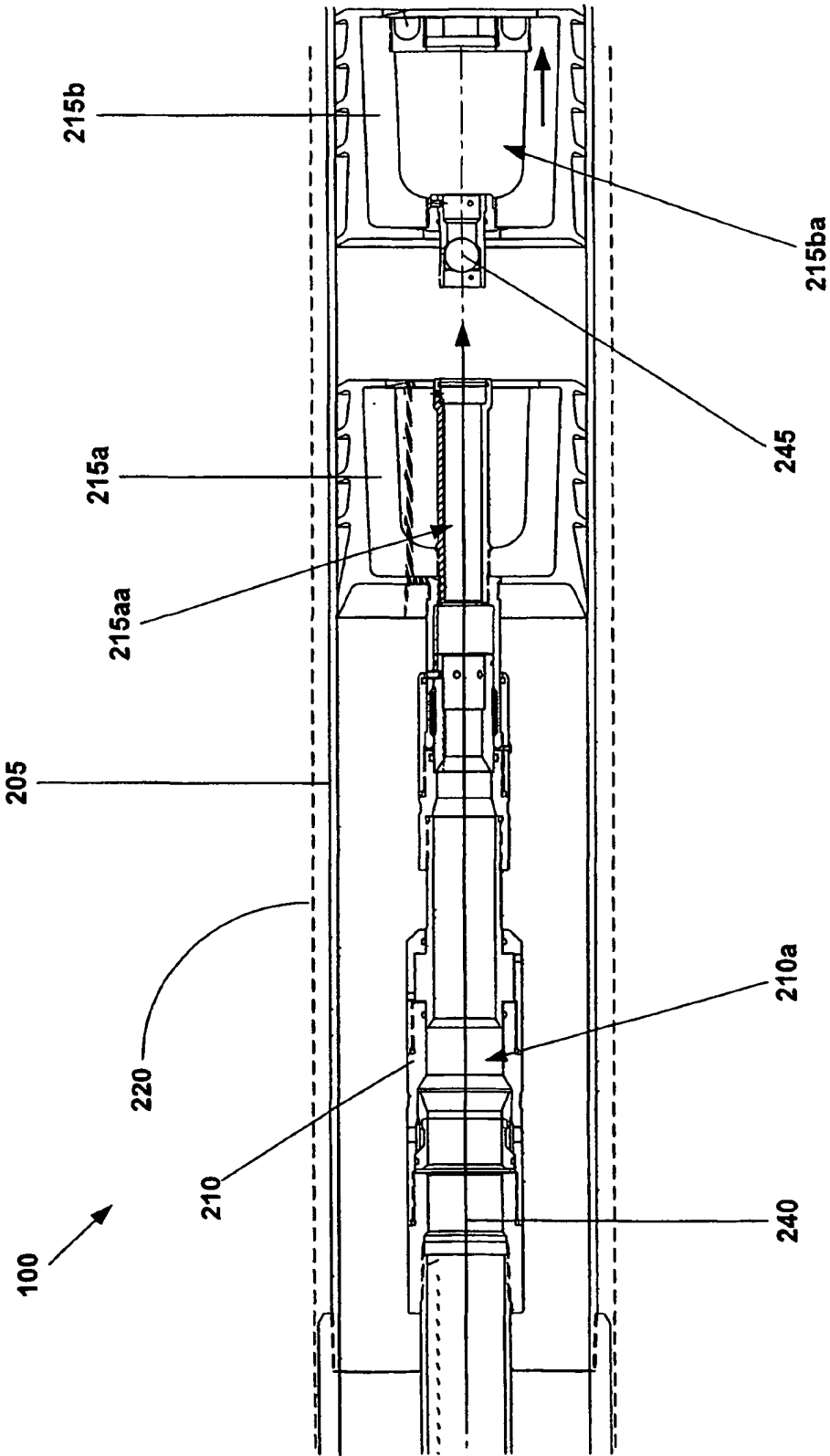

FIG. 3c



225

FIG. 3d

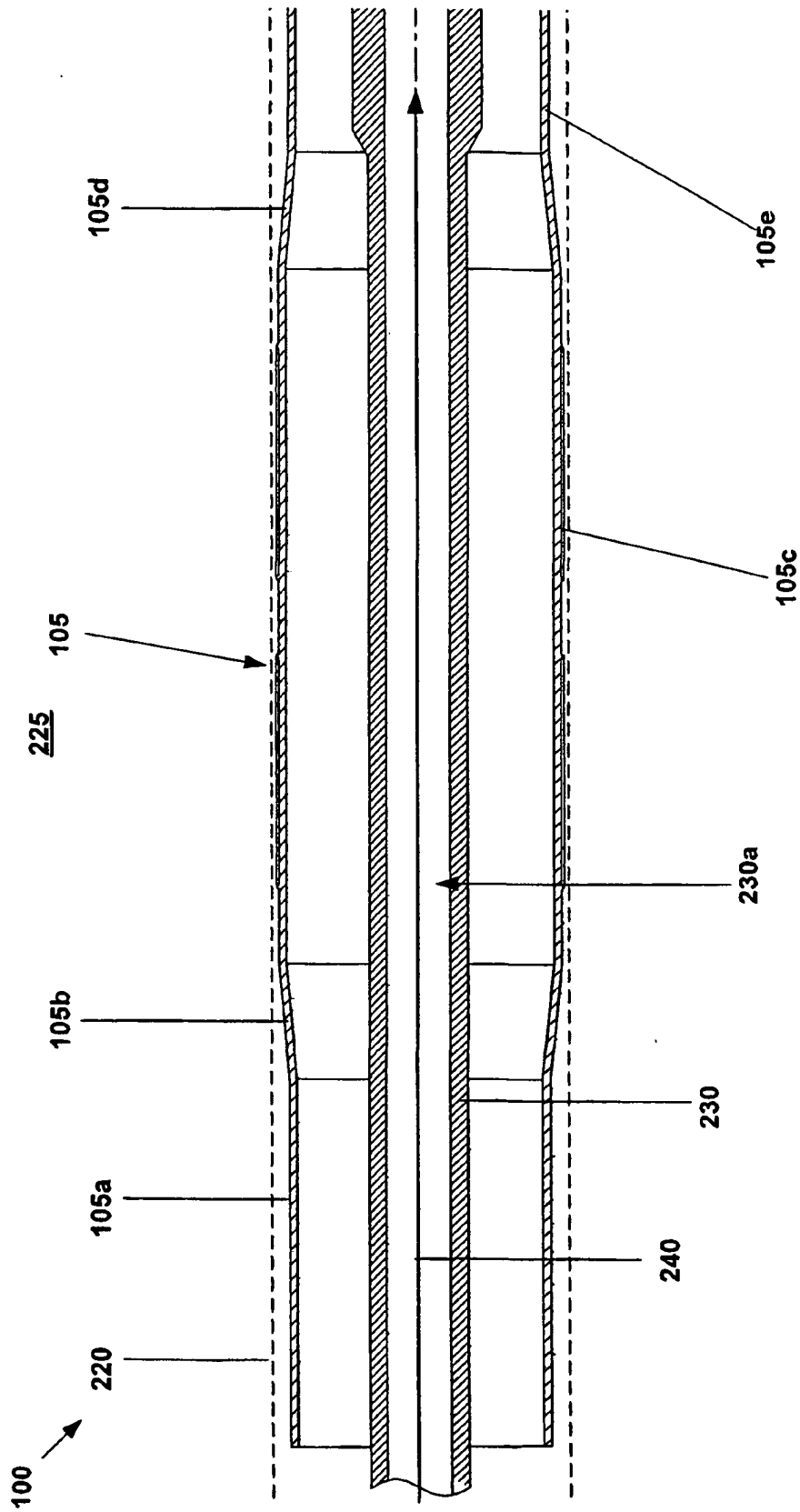

FIG. 4a

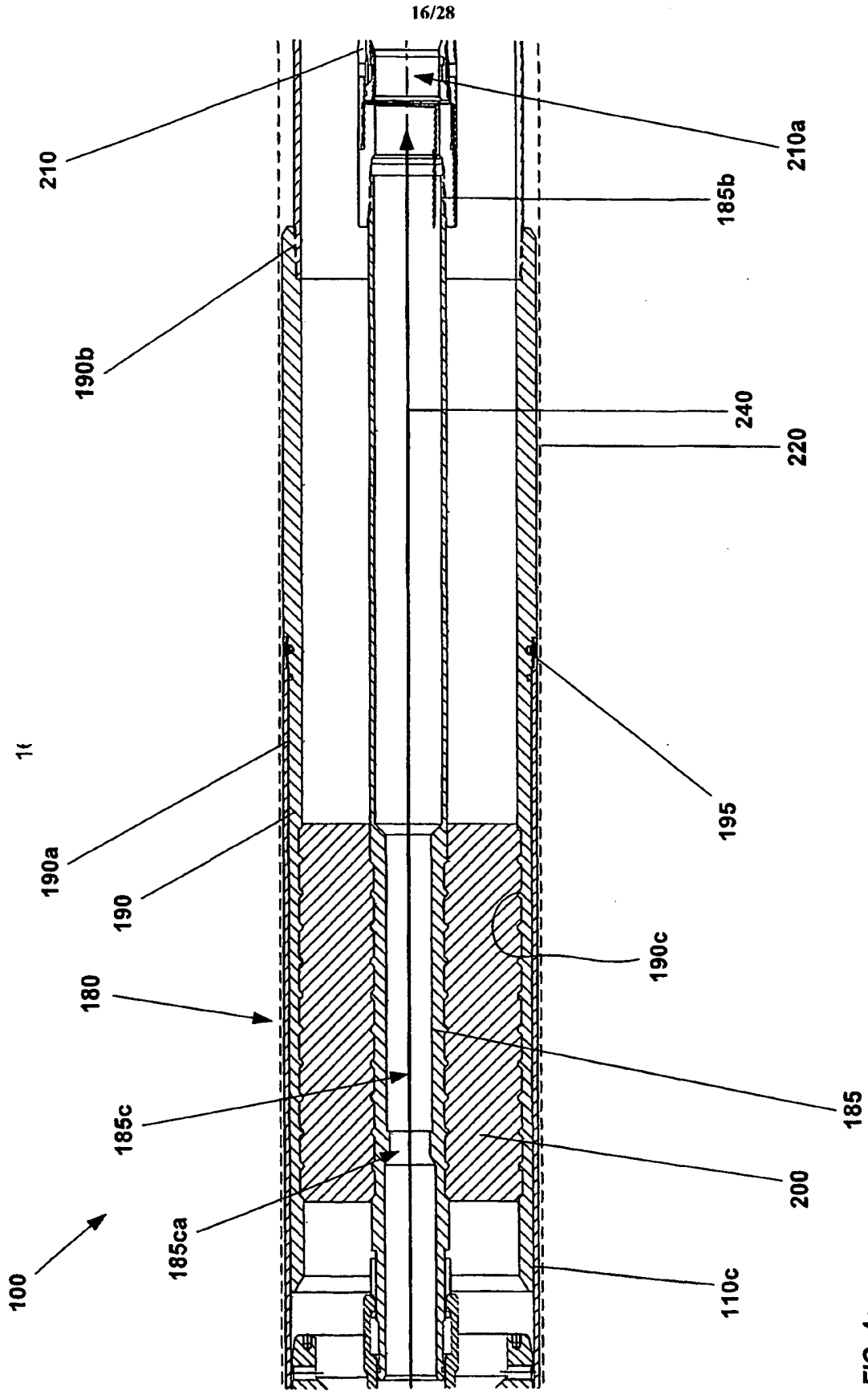

FIG. 4c

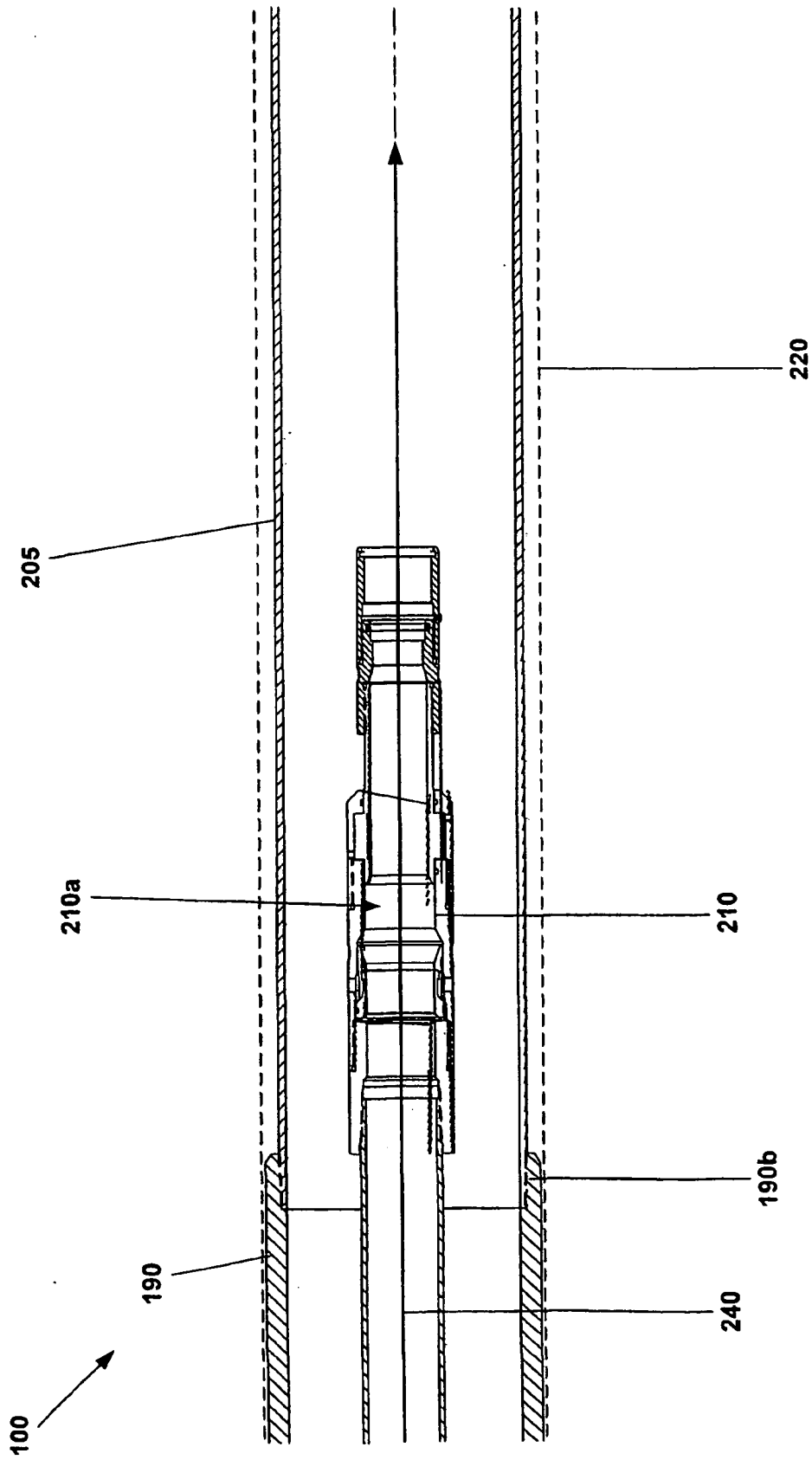
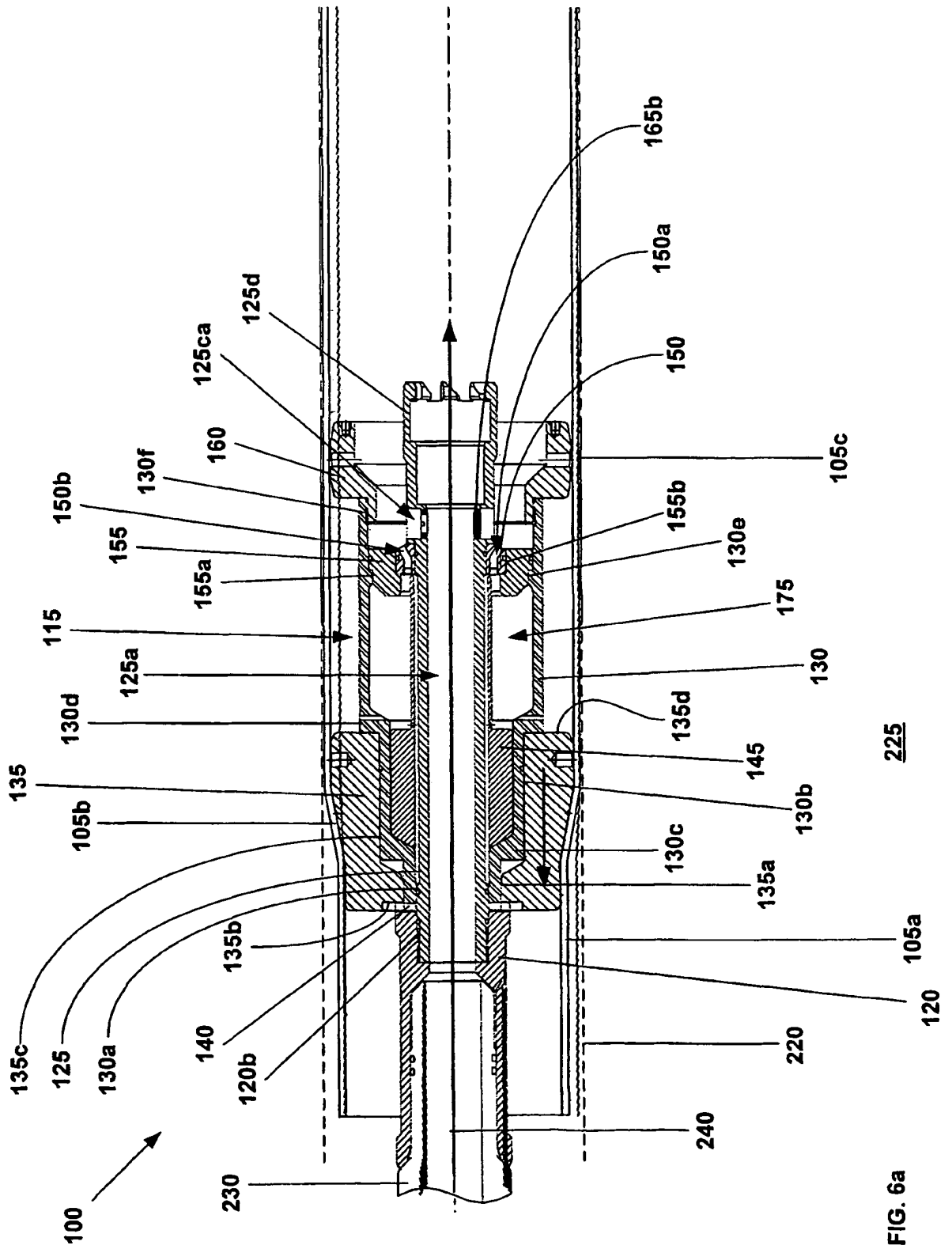

FIG. 4d



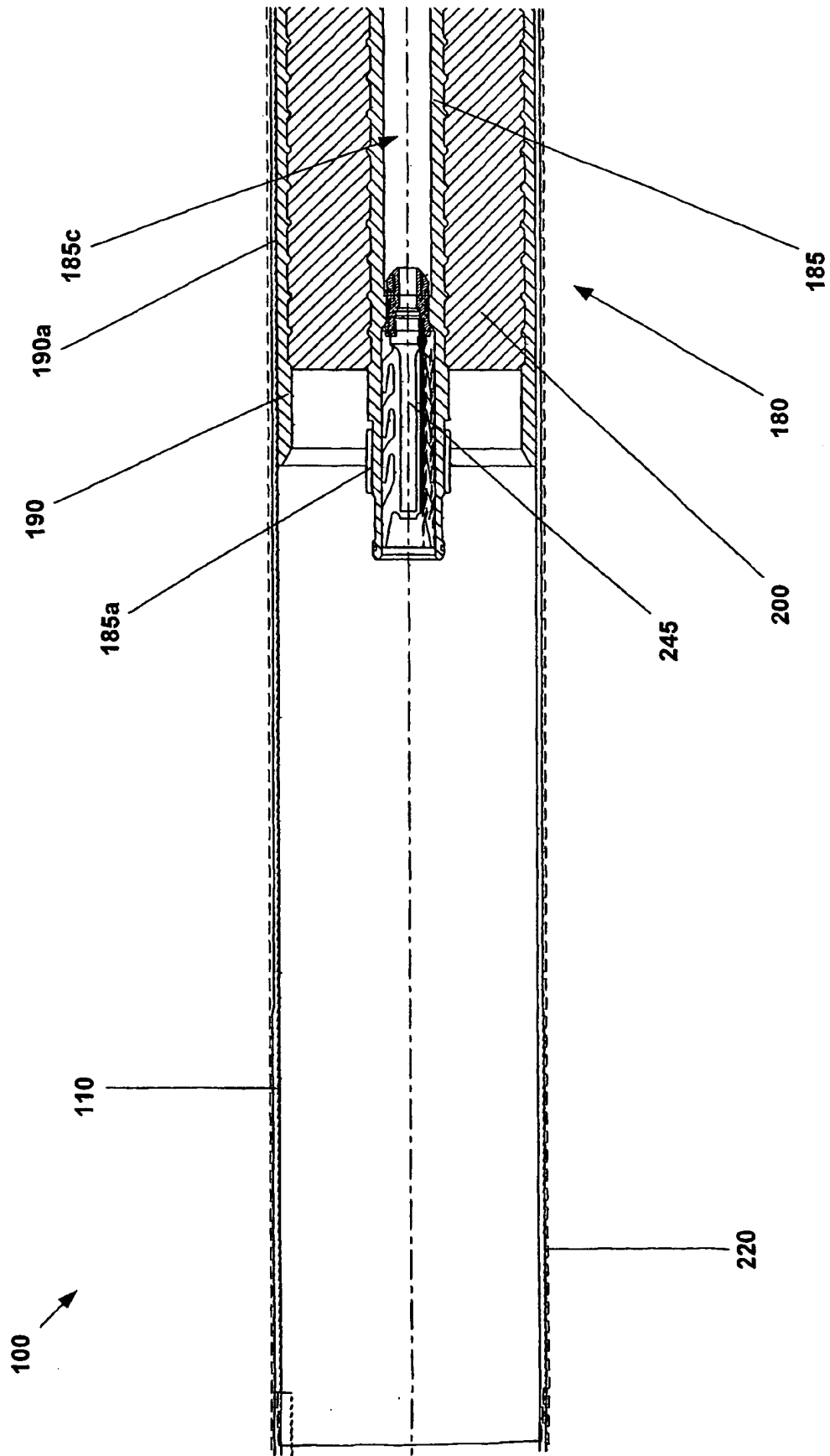
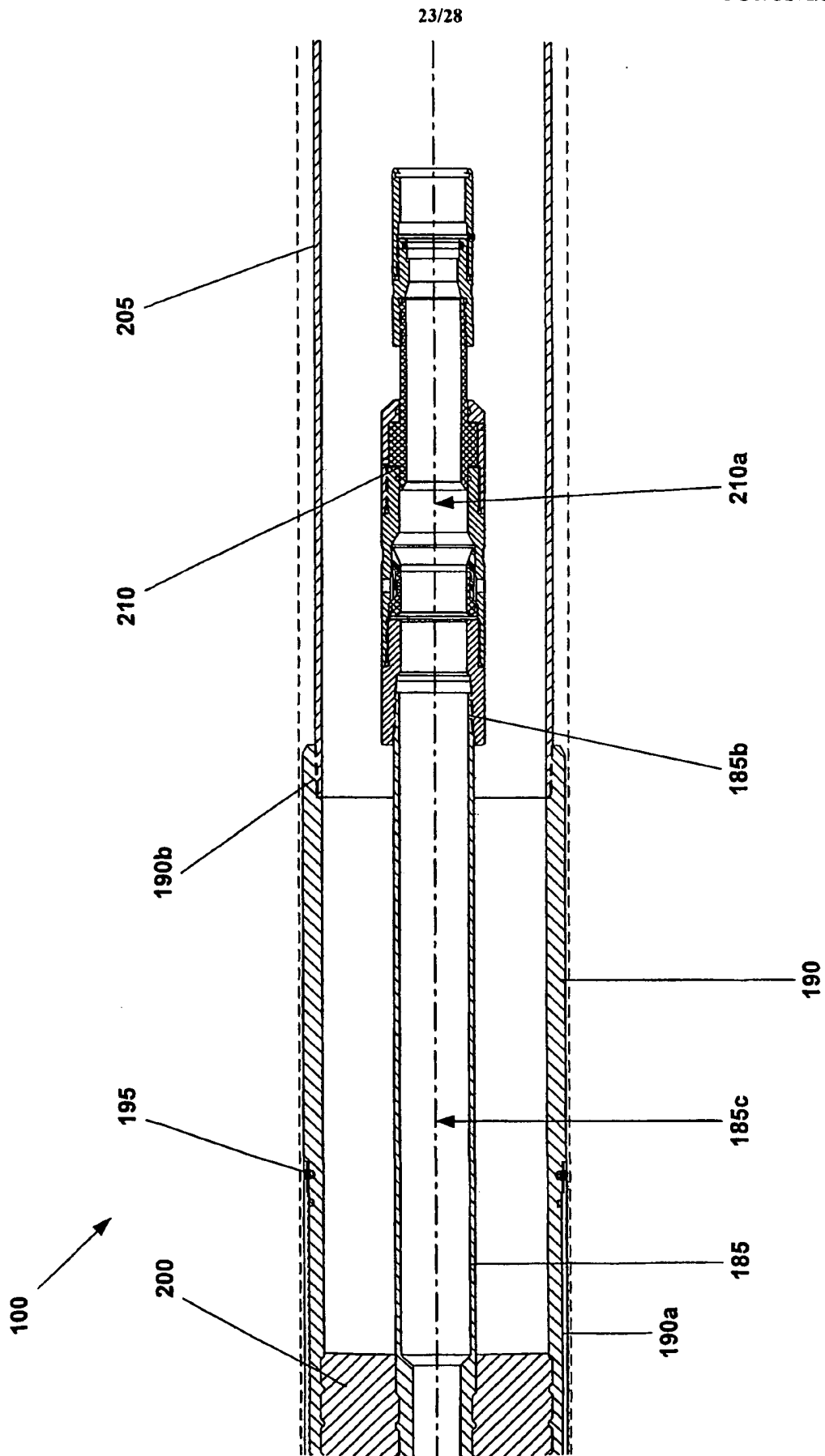

FIG. 6b



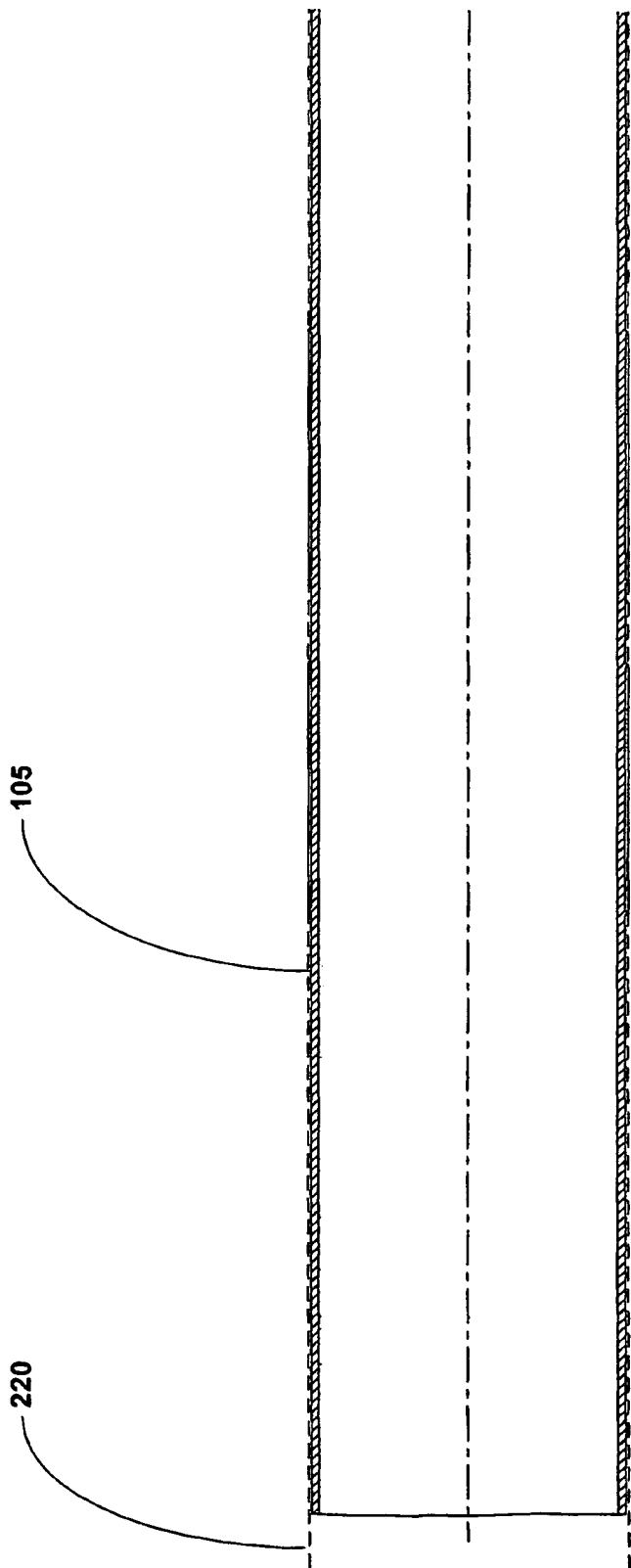

FIG. 7a

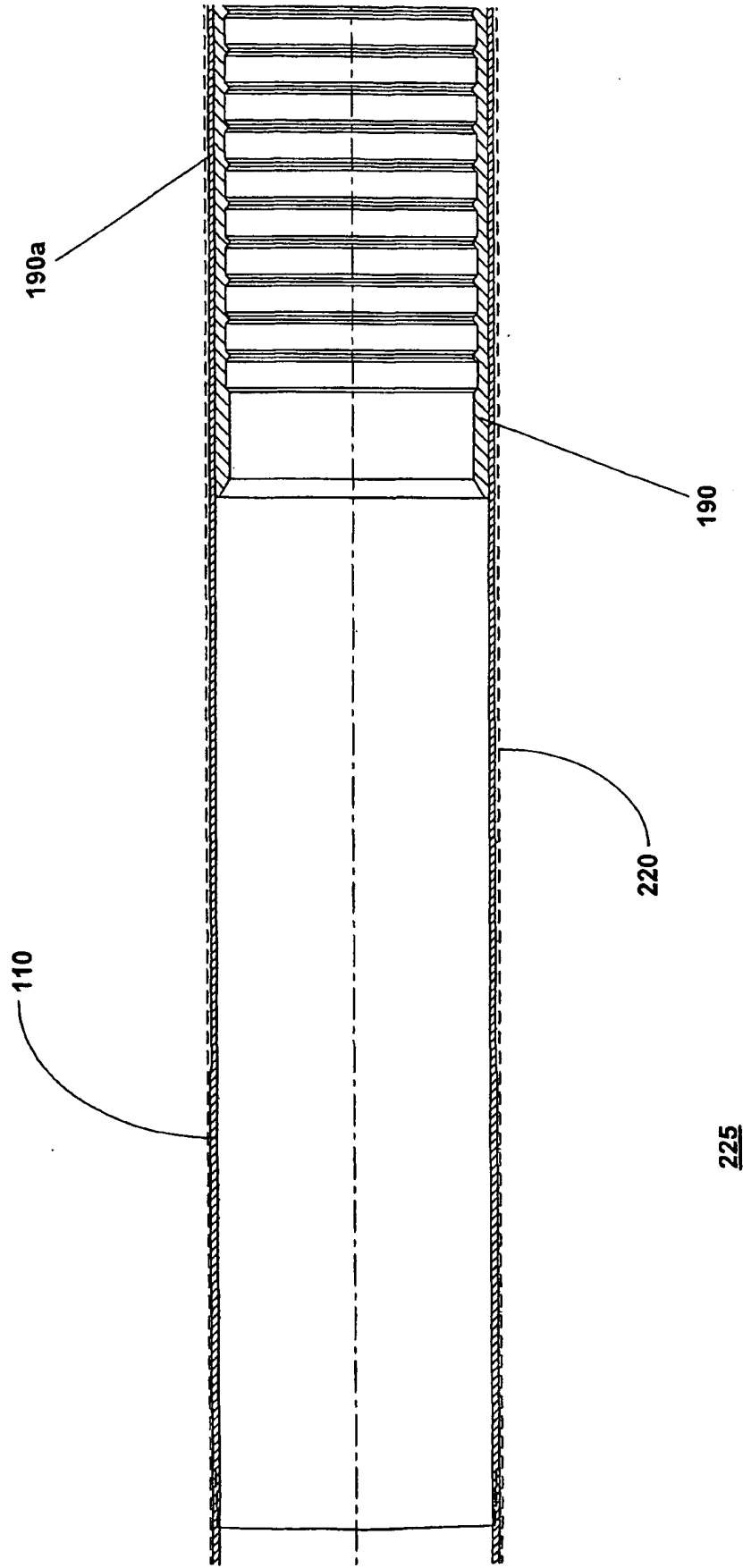

FIG. 7b

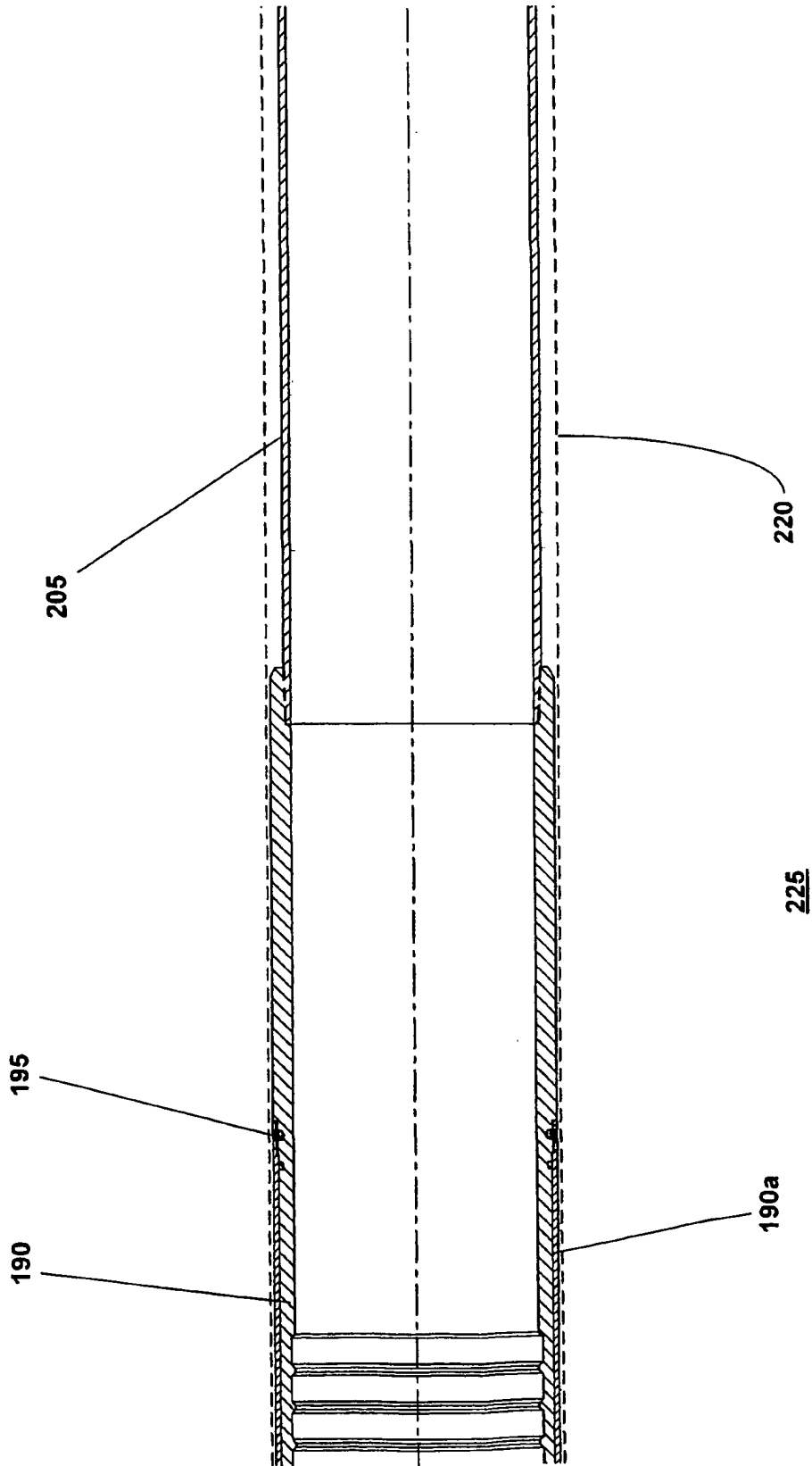
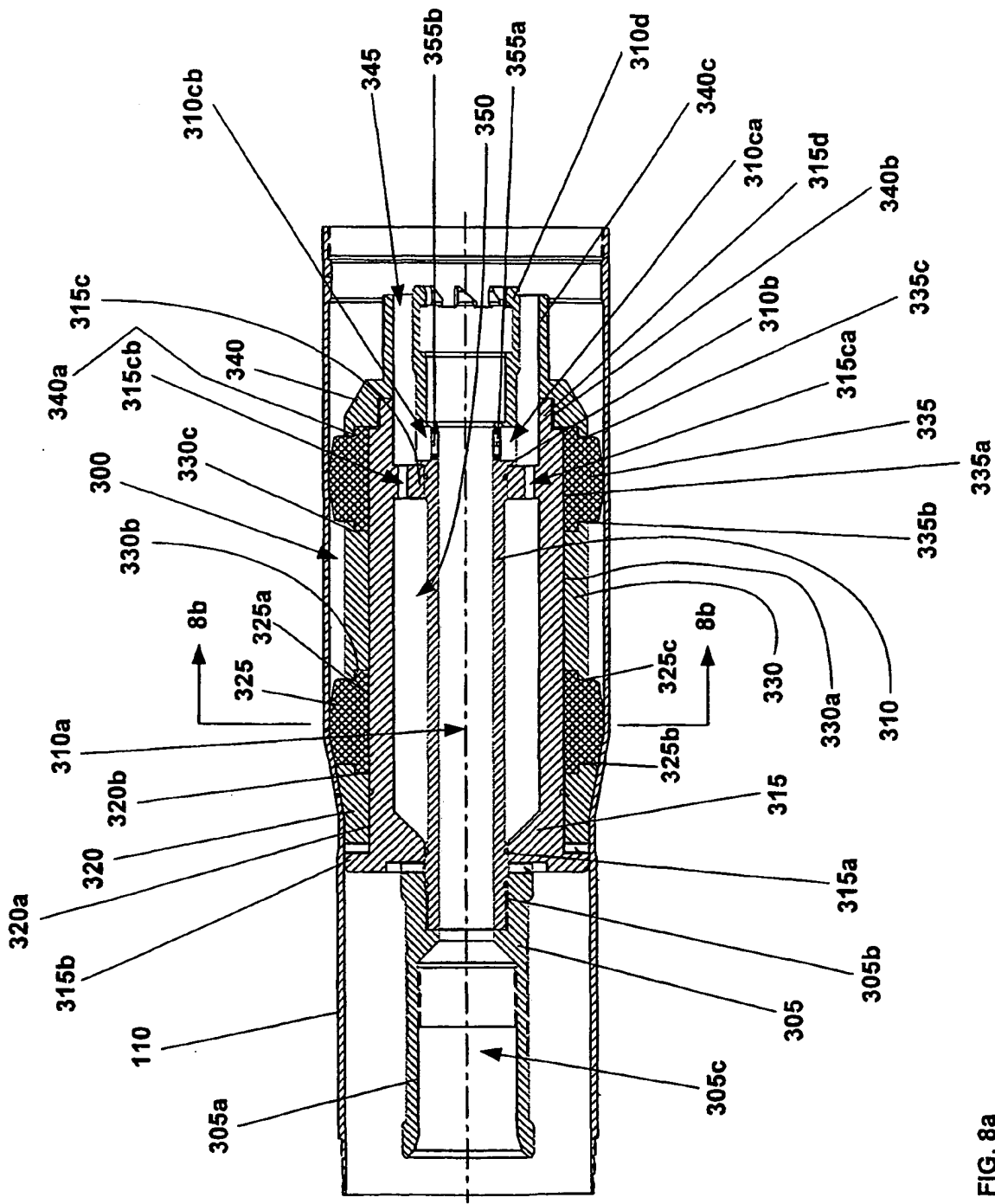

FIG. 7c



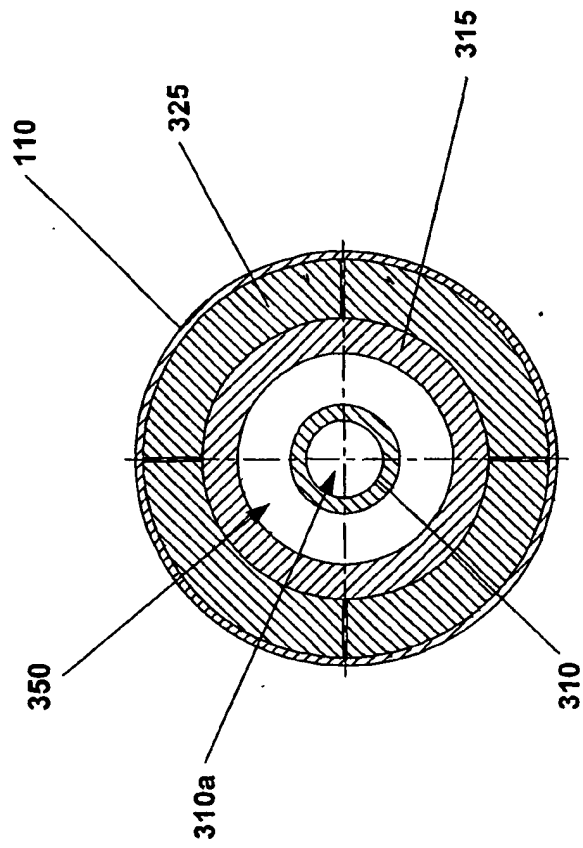

FIG. 8b